

OVERVIEW OF SOLUTIONS

Framo cargo pumping systems



Framo Cargo Pumping System

Framo hydraulically driven submerged cargo pumps provide safe, efficient and flexible cargo handling of any type of liquid cargo. Improved cargo handling performance gives quicker turnaround time, more ton-miles and fewer voyages in ballast.

Made to perform

The Framo cargo pump is of a robust construction made to efficiently empty any cargo tank containing the most heavy, viscous or aggressive cargoes.

The hydraulic driveline is designed for a safe and reliable pumping and final stripping of the most volatile or dangerous cargoes carried in bulk.

No risks of any build up of heat due to a fail-safe design where the pump motor and bearings are constantly lubricated and cooled by the hydraulic oil driving medium.

Save time

Spend less time on cargo operations

- **Quick cargo unloading**
- **Efficient stripping**
- **Less slop treatment**



High vessel utilisation
Clean seas

Load any type of cargo

The Framo cargo pump can handle any type of cargo. One voyage it may be a petroleum product, next voyage an acid or something heated/cooled/volatile or viscous.



Efficient switch between different cargoes

A cargo pumping system must be able to discharge, drain and clean the cargo tanks in an efficient manner to make the vessel ready to receive a new cargo.

Chemical tanker

M/T "Stolt Pride"
38,000 dwt Chemical tanker
Owner: Stolt-Nielsen, Netherlands
Built: Hudong, China, 2016



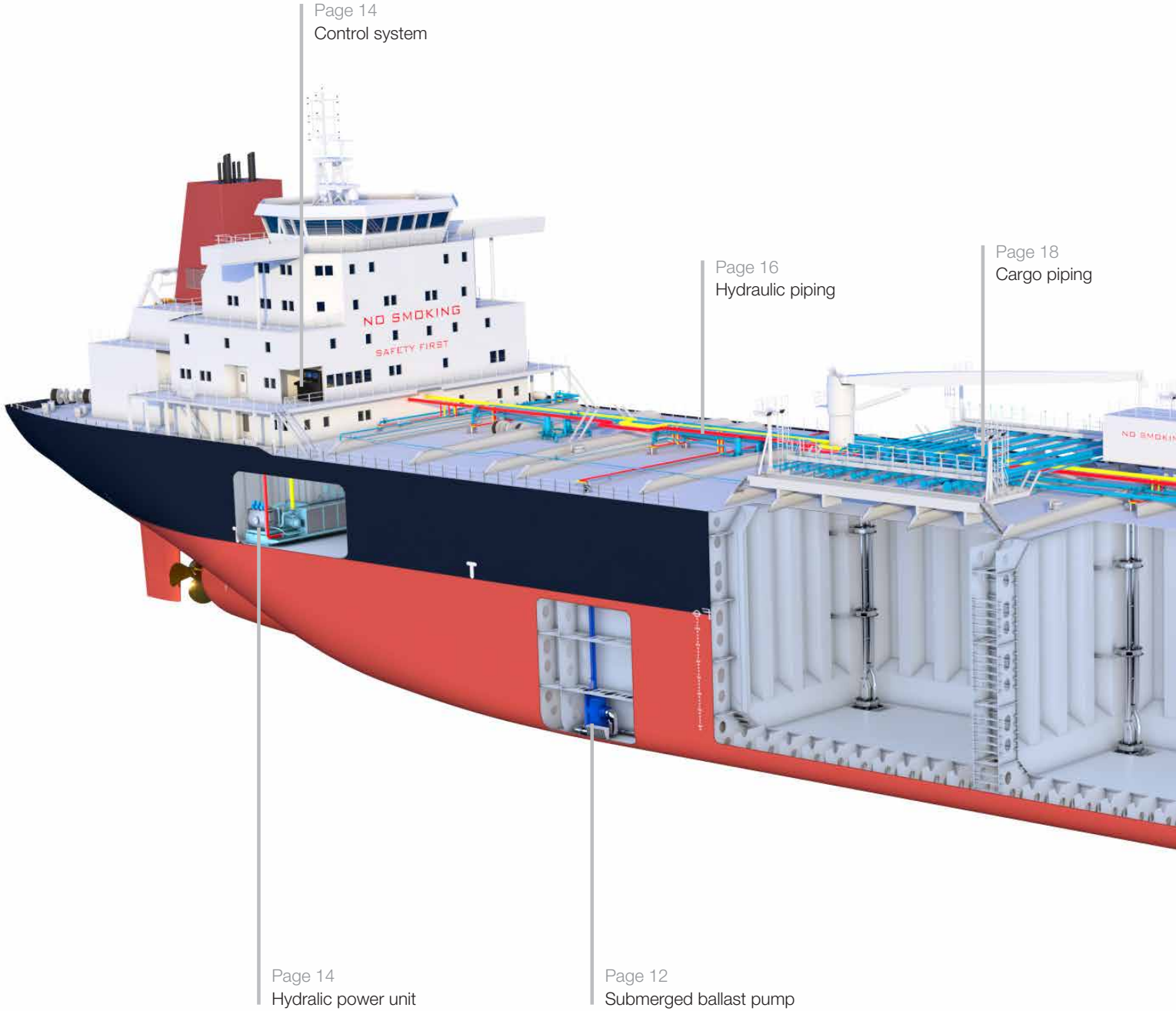

Page 14
Control system

Page 16
Hydraulic piping

Page 18
Cargo piping

Page 14
Hydraulic power unit

Page 12
Submerged ballast pump

Contents

- 2 Framo cargo pumping system
- 6 The submerged cargo pump
- 8 Safe operation
- 10 Cargo heating
- 12 Submerged ballast pumps
- 13 Submerged tank cleaning pumps
- 14 Hydraulic drive
- 16 Framo piping
- 18 Cargo piping
- 18 Cargo circulation
- 19 Cargo cooling
- 22 Floating production, storage and offloading
- 22 Framo cargo pumping systems
- 24 Technical data
- 26 Research and development
- 28 Customer support
- 30 Framo AS

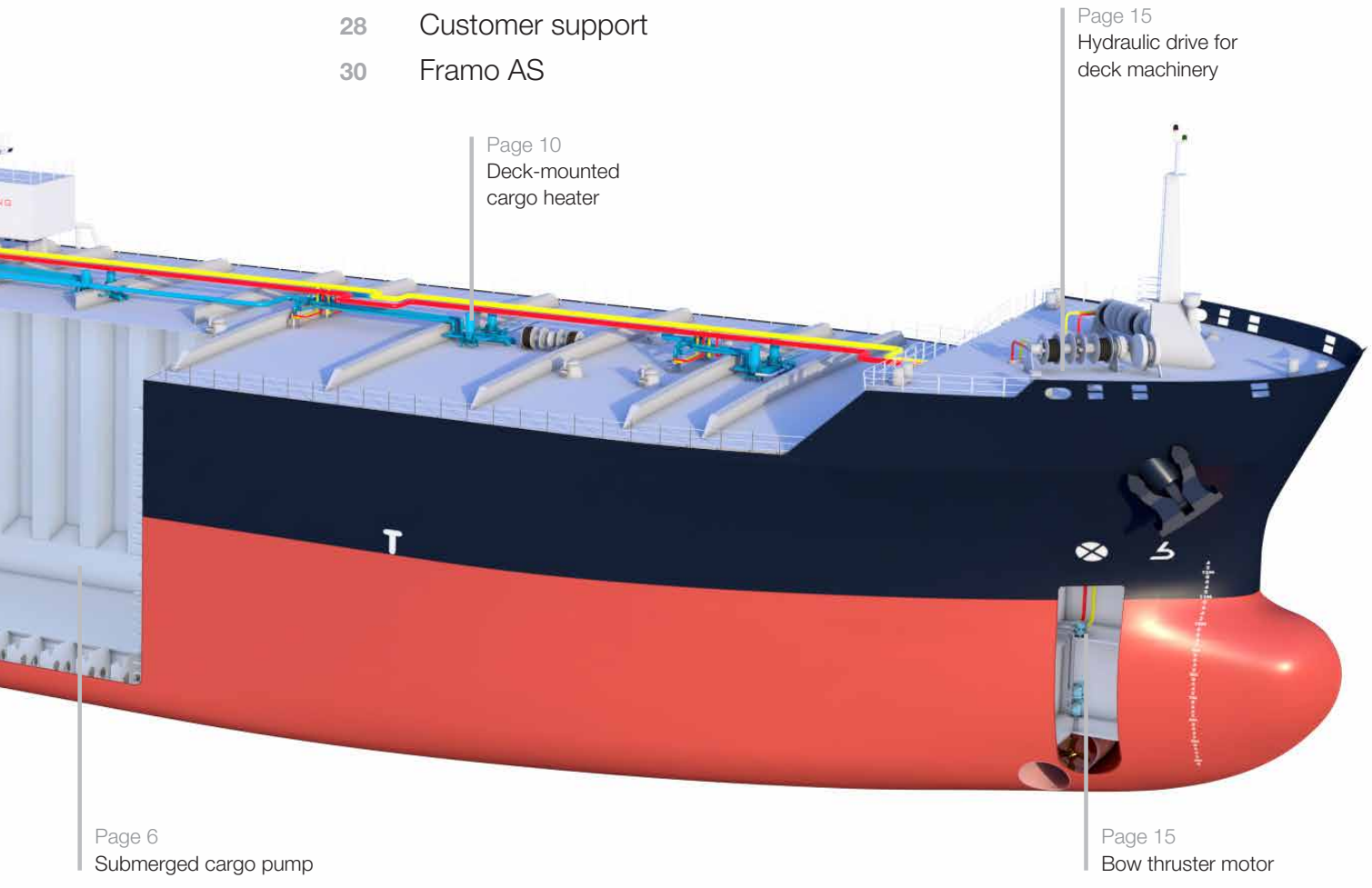

Page 6
Submerged cargo pump

Page 10
Deck-mounted
cargo heater

Page 15
Hydraulic drive for
deck machinery

Page 15
Bow thruster motor

The submerged cargo pump

The Framo cargo pump is a vertical single stage centrifugal pump powered by a hydraulic motor for safe and efficient operation.

All our cargo pumps are made in stainless steel material and designed with a smooth and easy-to-clean surface with a limited number of flanges which gives a superior ability to pump any liquid.

Design features

- Vertical single stage, single suction impeller, axially balanced
- Robust hydraulic drive with short and stiff drive shaft
- Fail-safe design; Lubrication and cooling of pump by the hydraulic driving oil medium
- Pump material stainless steel
- Concentric hydraulic pipes for maximum safety
- Cofferdam, ventilated to atmosphere, protecting the entire pump
- Mechanical seal against hydraulic oil
- Double lip seal against cargo, only exposed to static pressure
- Anti-rotation brake; loading through pump
- Smooth pump exterior; self draining and easy to clean

Performance

The Framo cargo pump is easy to operate. The hydraulic drive provides for a remote and local stepless capacity control through the Speed Torque Control (STC) valve on the pump's top plate. The cargo pump can pump anything liquid, regardless of specific weight or viscosity.

It is impossible to overload or to over-speed the pump. The STC valve auto-matically regulates hydraulic oil pressure and flow to the hydraulic motor according to the given discharge situation.

The pump design allows operation with a minimum of liquid in the tank which saves time spent for drainage and tank cleaning. The Framo cargo pump has a built-in efficient stripping system.

Condition based maintenance

Seal monitoring is performed from the cargo pump top plate by purging the cofferdam.

Replacement of wear and tear parts is easily done from inside of the tank without interfering with the hydraulic section.



Framo cargo pump in tank



STC valve on cargo pump top

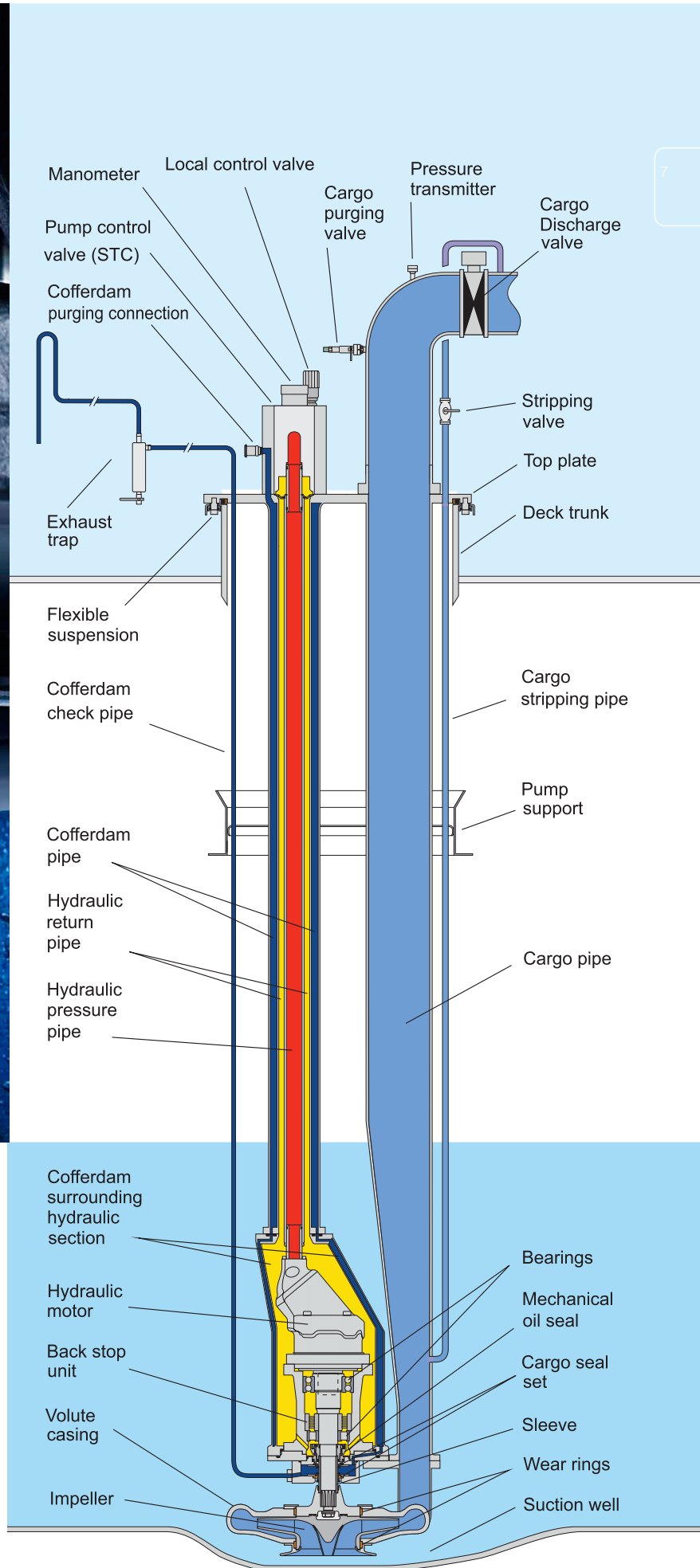

The hydraulic high pressure pipe is located inside the low pressure return oil pipe. The entire hydraulic section is separated from the cargo by a cofferdam ventilated to atmosphere.





Safe operation

Dangerous chemicals, acids, oils or edibles must be handled in a safe way for people and environment. The tanker must be equipped with cargo pumps that can efficiently empty cargo tanks and associated cargo piping to meet the most stringent requirements, and withstand the tough impact during hours of tank cleaning afterwards. Switch between cargoes without cargo contamination. Carry anything from acids to drinking water.

High specific gravity

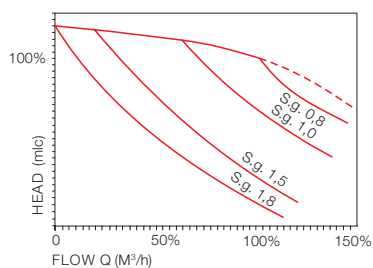

- Hydraulic drive and torque control, no risk of overloading
- Any specific gravity of cargo, no limitation

High Viscosity

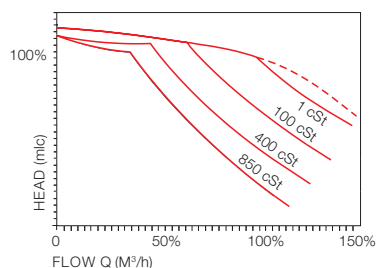

- Full torque at any speed
- Extremely viscous cargoes, molasses etc.

Terminal back pressure

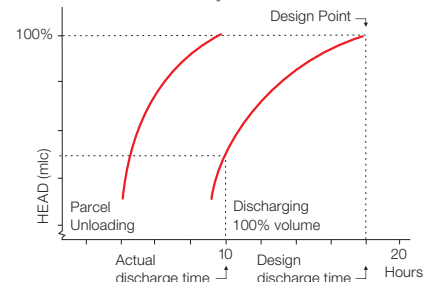

- Increase the discharge rate at lower back pressure
- Shorter discharge time

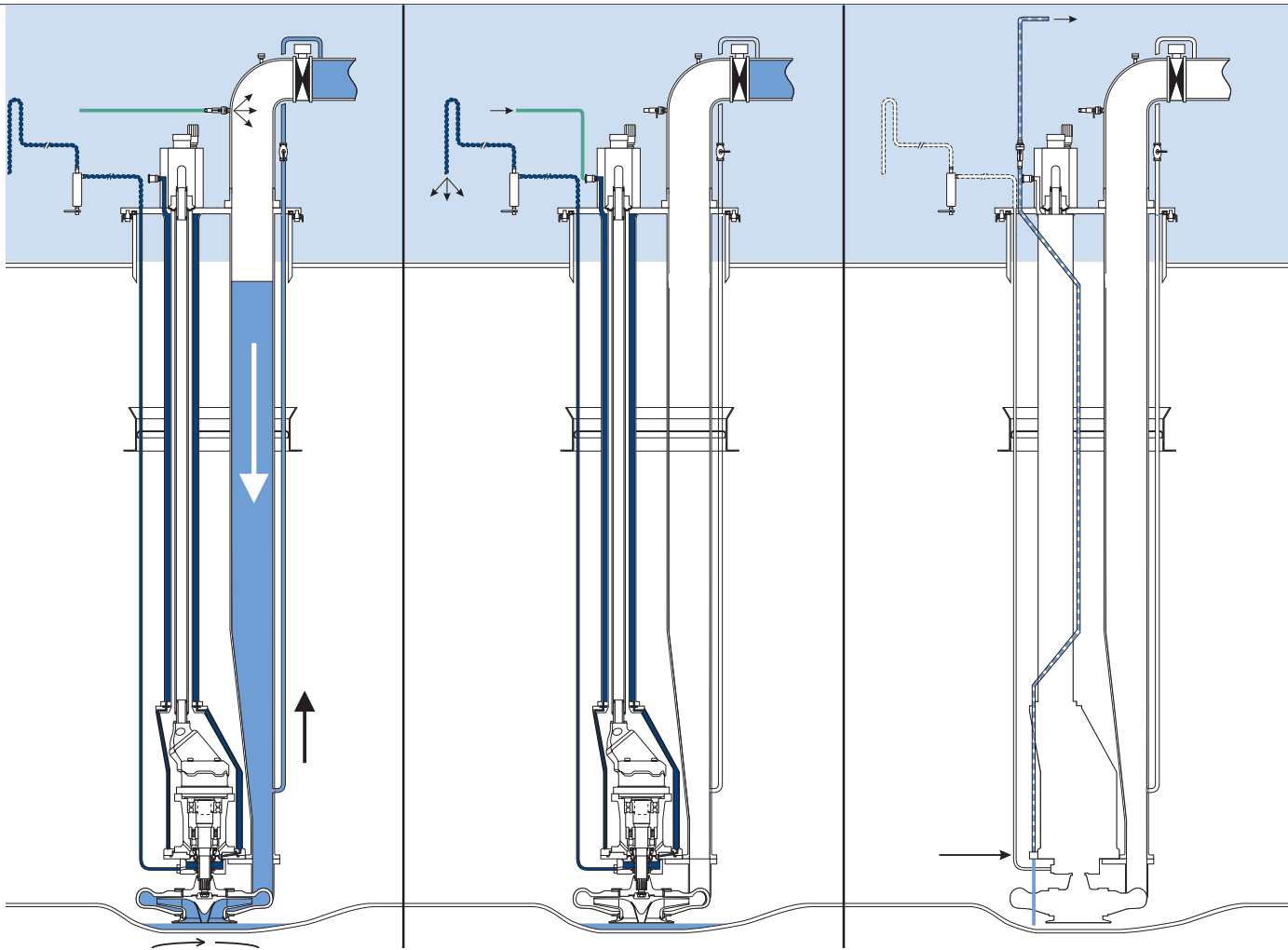

Stripping

When the cargo tank is empty, the speed of the cargo pump is reduced to perform the final stripping of tank:

- Close the cargo valve
- Open the small ball valve on the stripping line
- Pressurize the pipe stack by connecting the purging hose with compressed air or nitrogen
- Press cargo out through the stripping line and into the cargo line

The pump impeller rotates and acts as a non-return valve to prevent cargo from returning back to tank.

Purging and seal monitoring from deck level

The pump's cofferdam is purged before and after discharge operation. Any leakage across the cargo seals or hydraulic oil seals collected in the cofferdam, will be forced to the exhaust trap on deck where it can be measured.

This is a simple and reliable seal condition monitoring system. No need for any electric sensors nor any automatic control system.

Vacuum drain

The standard Framo cargo pump design meets all applicable rules for stripping under the IMO Annex II requirements.

However, as an option, the Framo cargo pump can be equipped with a vacuum drain line that will empty suction well completely and allow for a dry tank top and quick re-loading of cargo.

High or low temperature, volatile and dangerous cargoes

The Framo cargo pump is designed for any cargo temperatures prevailing in tankers. The pump is continuously temperature controlled by the circulating hydraulic drive oil.

The Framo cargo seal arrangement is exposed to static cargo tank pressure only.

Optimal operating conditions are maintained at all pumping conditions. Volatile or heat sensitive cargoes can be discharged efficiently in a safe manner.



Stainless steel chemical tankers

Ship of the Year 2019

The stainless steel chemical tanker fleet comprises the most sophisticated tankers sailing on the high seas. These ships are constructed with stainless steel cargo tanks, a fully segregated cargo pumping arrangement and designed to carry the most aggressive, corrosive or volatile liquids.

M/T "Bow Orion"
49,000 dwt
Chemical tanker
 Owner: Odfjell SE, Norway
 Built: Hudong Shipyard, China, 2019

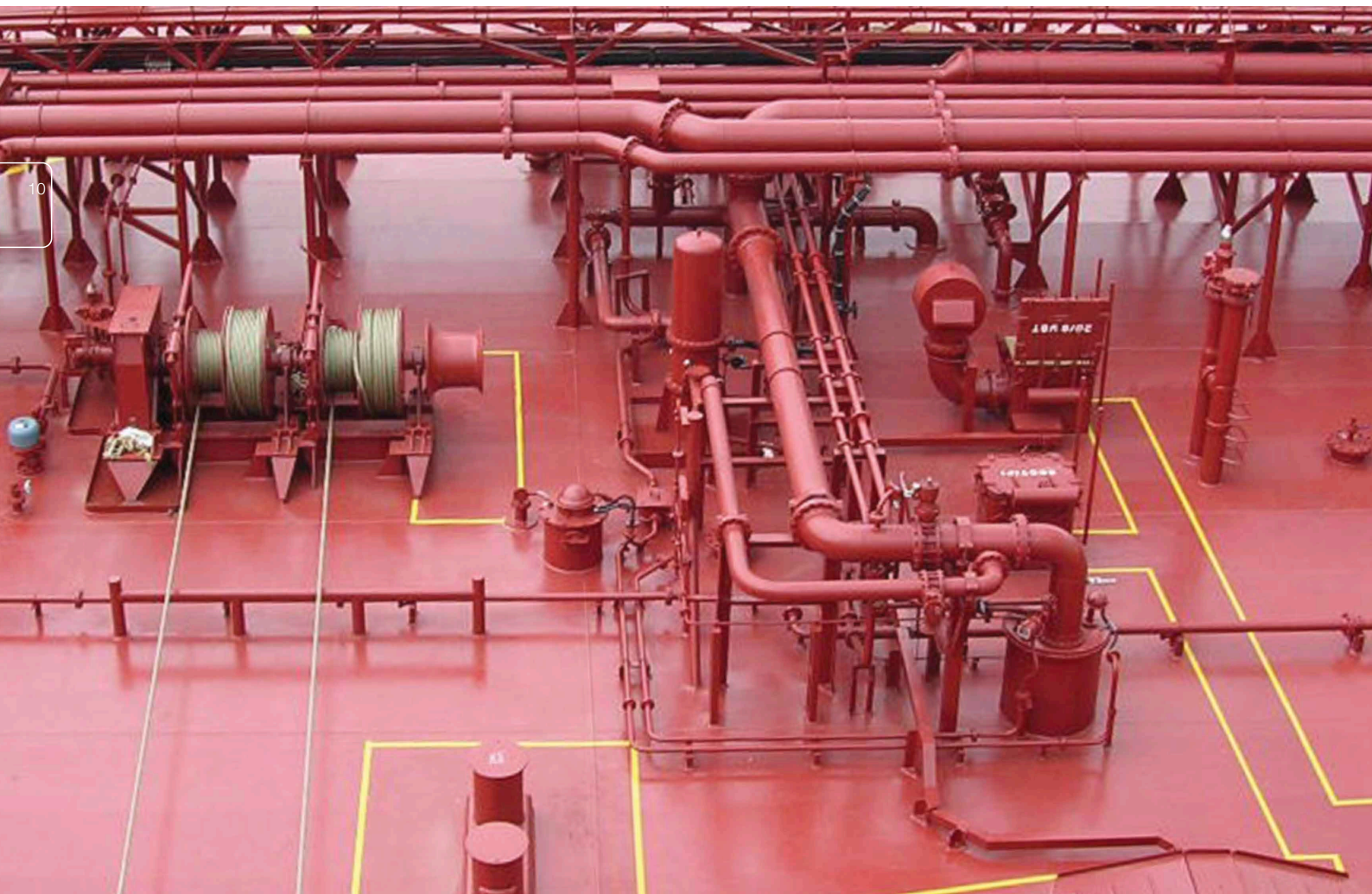

Cargo heating

Framo deck mounted cargo heaters eliminate the need for in-tank heating coils. The cargo tank interior can be made with flush tank top free from coils, brackets and clamps. A flush tank top facilitates quicker stripping with less cargo remaining in the tank. The cargo tank washing can be performed quicker, with less consumption of washing water and less slop handling.

Performance

High flexibility to heat all traded cargoes, such as heavy fuel oils, oil products, palm oils and other chemicals that may be temperature sensitive and requires a gentle heating procedure.

The specially shaped heating elements secure easy cargo circulation and have a low surface temperature against cargo.

The high capacity and low pressure drop through the cargo heater gives a low power

consumption during circulation and secure a good mixing and heat distribution inside the cargo tank.

The heating medium can be saturated steam, hot water or thermal oil.

Framo deck mounted cargo heating system is supplied as an integral part of the cargo pumping system for all sizes of oil tankers, chemical tankers and FPSOs.

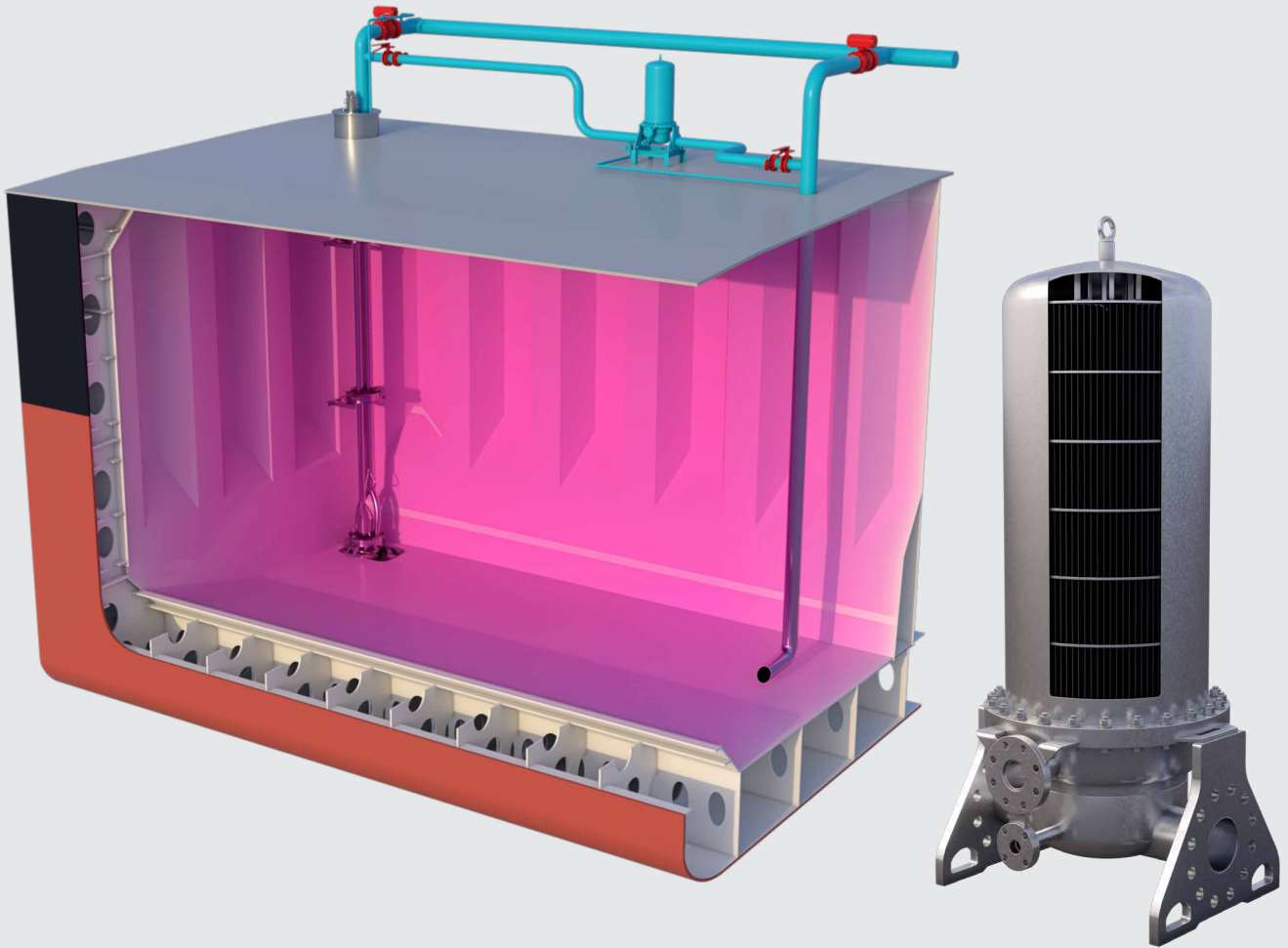

Cargo heating

- Circulate the cargo through the deck mounted cargo heater
- Adjust heating capacity to meet cargo requirements
- Heat gently with careful temperature increase across the heater
- High circulated cargo flow gives a good heat distribution inside the cargo tank

Design features

- Made for a tough marine environment
- Stainless steel
- Compact welded plate type design
- Large heating surface
- Low pressure drop
- Vertical self draining
- Easy to clean
- Easy to inspect
- Cargo heater is only exposed to cargo when in use



Chemical/product oil tankers

Most of the world's production of vegetable oils, commodity chemicals and refined petroleum products are transported on the large fleet of modern chemical/product tankers. Typically designed with coated cargo tanks, six to eight cargo segregations, no pump room, submerged ballast pumps, in-tank cargo pumps and deck mounted cargo heaters.

M/T "Yasa Pelican"

50,000 dwt
Product tanker
 Owner: Yasa, Turkey
 Built: HMD, Korea, 2019

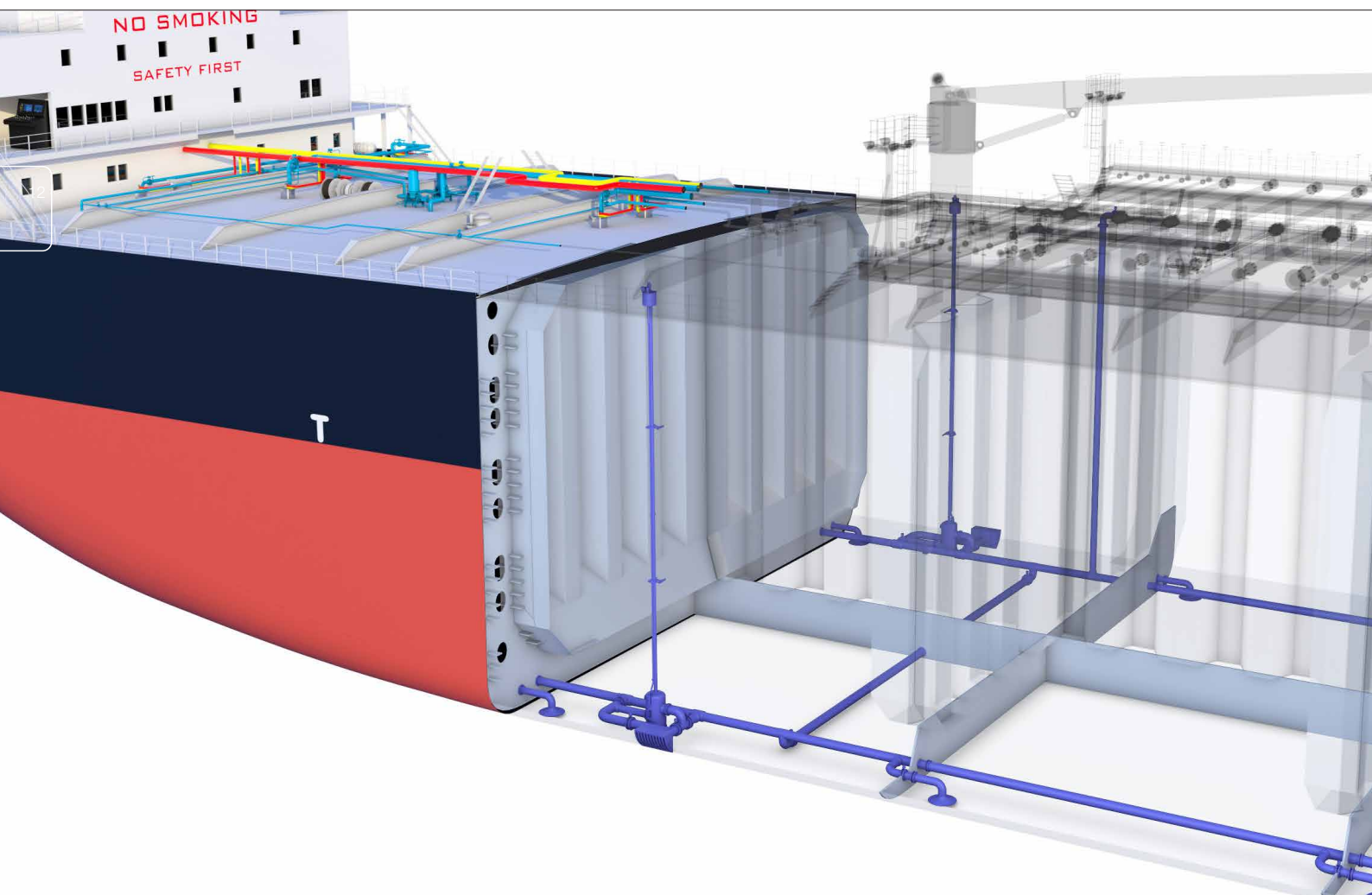

Submerged ballast pumps

Installation of ballast pumps inside the double side ballast tanks in combination with a submerged cargo pump in each cargo tank make the pump room superfluous. This arrangement provides a safer ship design and make more space available for carrying cargo. Submerged ballast pumps have become the standard arrangement in modern tankers and FPSOs.

Submerged tank cleaning pumps

The Framo submerged tank cleaning pump is based on the submerged cargo pump design and equipped with a suction arrangement to allow for suction from sea chest and technical fresh water tank.

Framo also supply a range of tank cleaning pumps for dry installation. Any Framo pump with hydraulic drive is 100% explosion proof, and can be installed in hazardous areas.

Increased cargo volume

Normally installed inside two of the double side ballast tanks located aft of the manifold area, one in each side. On oil tankers, a fuel-oil tank can separate the engine room and cargo section.

- No pump room required
- Larger volume available for cargo

Submerged installation

The Framo submerged ballast pump is a centrifugal pump, designed for installation inside the ballast tanks.

The pump unit is mounted inside the air separator and protected by a cofferdam. A fail-safe design ensures that impeller will always be immersed in water.

Design features

- Impeller always immersed in water
- Built-in self priming system

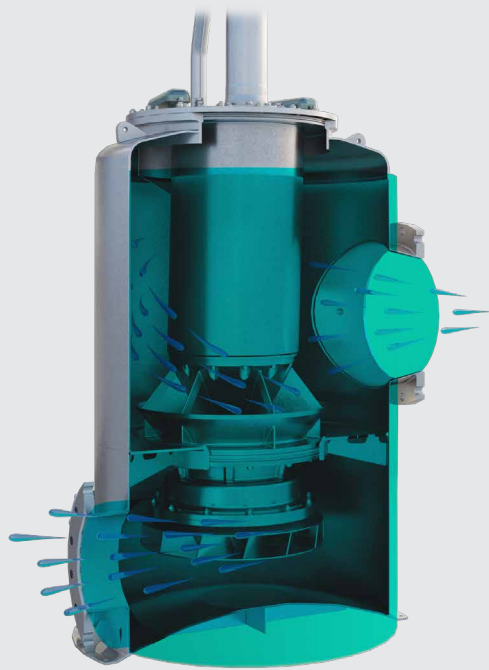
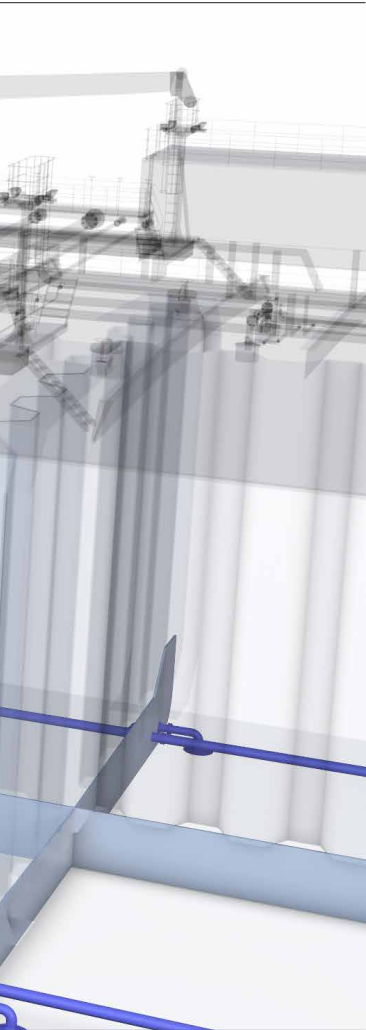

Increase the cargo volume with submerged ballast pumps. Eliminate the pump room. The Framo ballast pump has a fail safe design with impeller always immersed in water.

- Individual capacities of up to 3.000 m³/h
- Stepless capacity control
- Robust design with a short and rigid drive shaft
- Lubrication and cooling of motor and bearings by the hydraulic drive oil
- Cofferdam between ballast water and hydraulic section
- Concentric hydraulic pipes for maximum safety
- Easy to install, operate and maintain
- Can be connected to any ballast water treatment system

This is a compact design which saves space and makes the installation easy. An air ejector is connected to the pumps suction side. Automatic start and stop of the air ejector makes the pump self priming.

The pump is manufactured from stainless steel with seawater resistant bronze impeller.

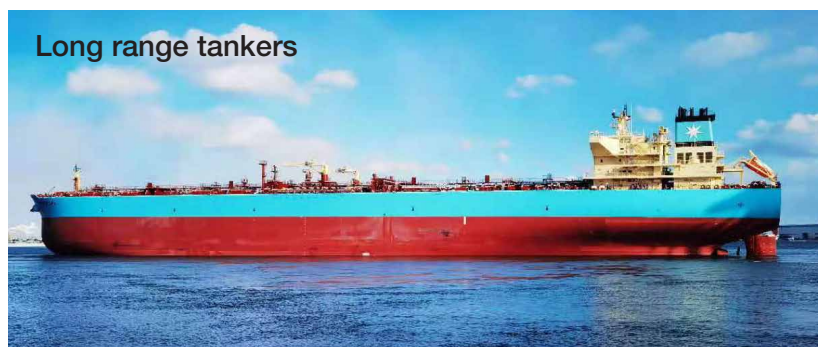

Long range tankers

Long range tankers

The use of one submerged hydraulically driven cargo pump per tank provides safe segregation between cargoes. It makes the stripping and tank cleaning quicker. Efficient switch between cargoes gives a substantially higher number of ton miles.

M/T "Maersk Sandra"
115,000 dwt LR tanker
Owner: A.P. Møller-Maersk, Denmark
Built: Dalian, China, 2020

Hydraulic drive

A complete system designed and manufactured by Framo. Hydraulic drive provides the most flexible and safe power transmission for a cargo pumping system on tankers.

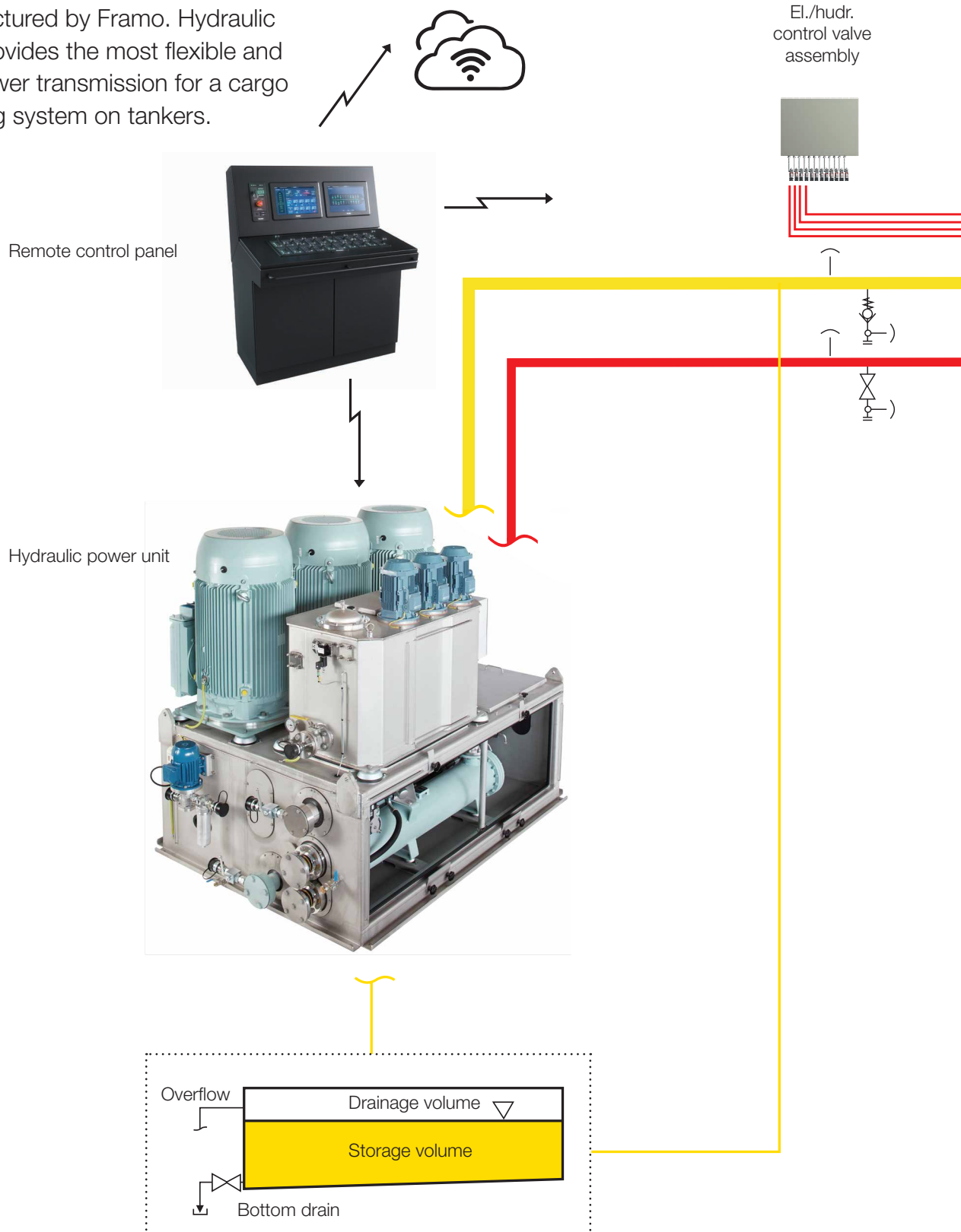



Portable pump



Tripod for portable pump



Cargo heater

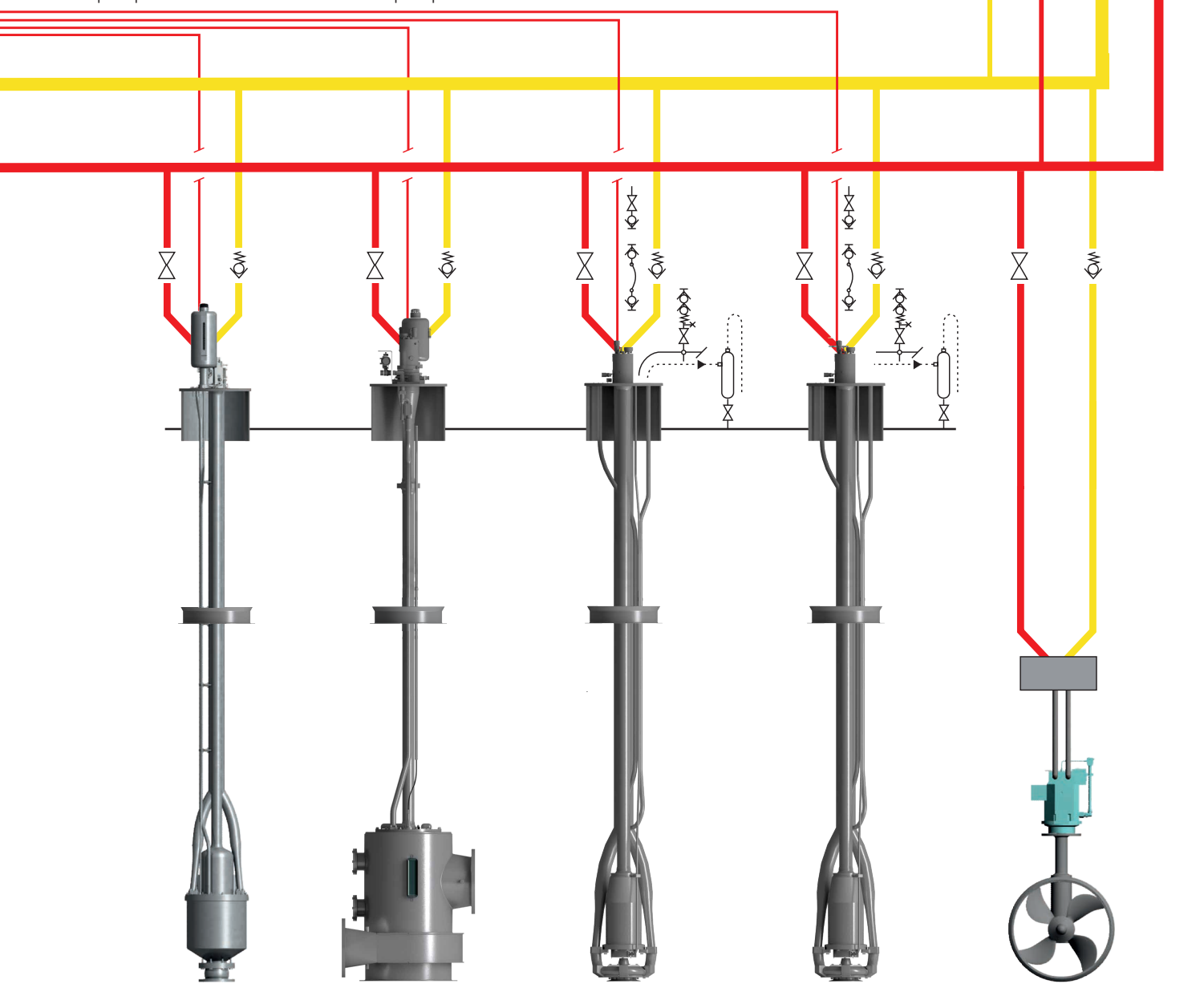
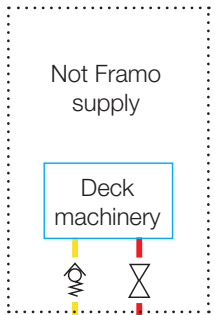

Submerged tank cleaning pump

Submerged ballast pumps

Submerged cargo pumps

Submerged cargo pumps

Bow thruster

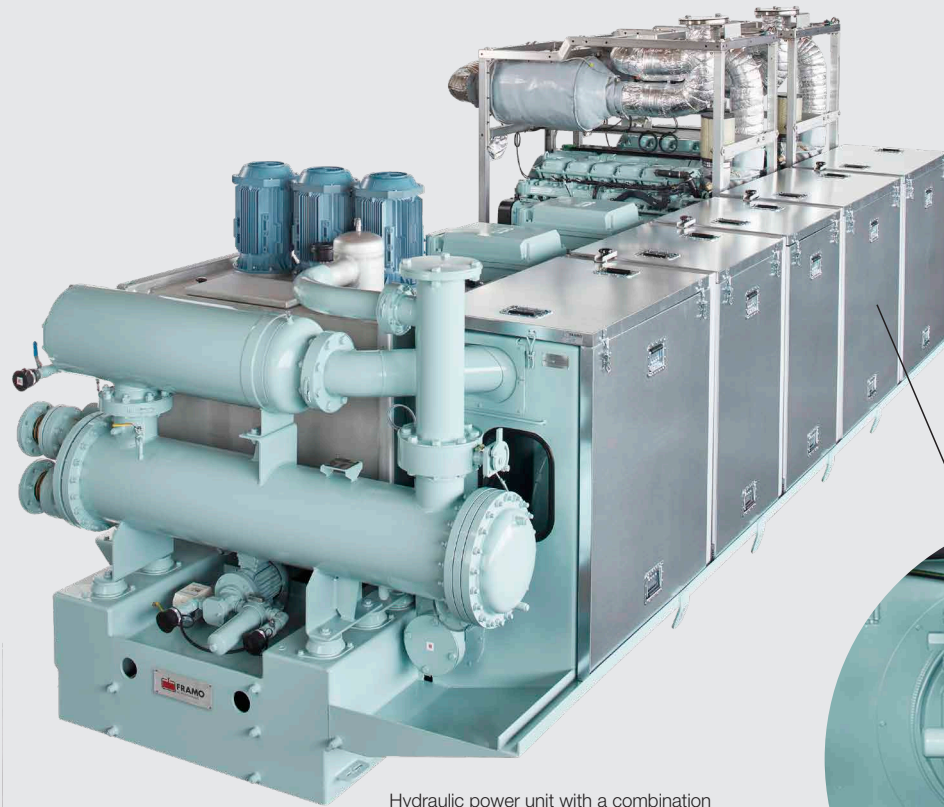

Hydraulic power unit with a combination of electric motor driven power packs and diesel engine driven power packs for medium and large sized tankers.

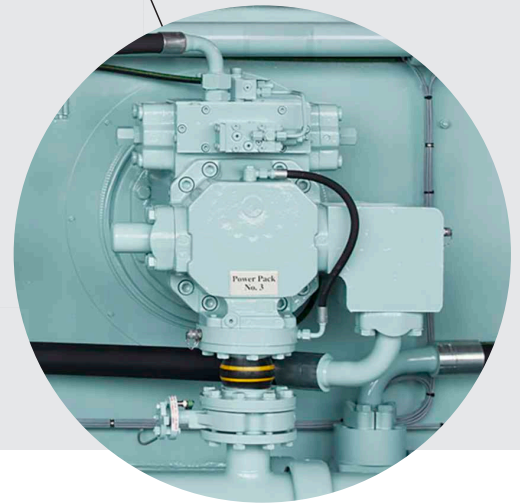

Hydraulic system and control panel

Hydraulic power unit

The hydraulic power pack prime movers can be electric motors or diesel engines.

A combination of electric motor and diesel engine prime movers allows the ship's generators to be designed for the relatively low power requirement in sea-going mode rather than the considerably higher requirement during cargo unloading. The ship's auxiliary engines can therefore operate with an economic load while at sea where the majority of running hours will be. The diesel hydraulic power packs will provide any additional power needed for a high capacity/high head cargo discharge.

All power packs, stainless steel system tank, oil cooler, and full flow filter are mounted, piped and wired on a module for resilient installation onboard.

This Hydraulic power unit is full scale tested together with the control system module before shipment.

The hydraulic pumps are of the variable displacement type and fitted with a pulsation damper for maximum reductions in pulses and noise.

A power saving device incorporated into the Framo control system automatically regulate and share the load between each power pack in operation.

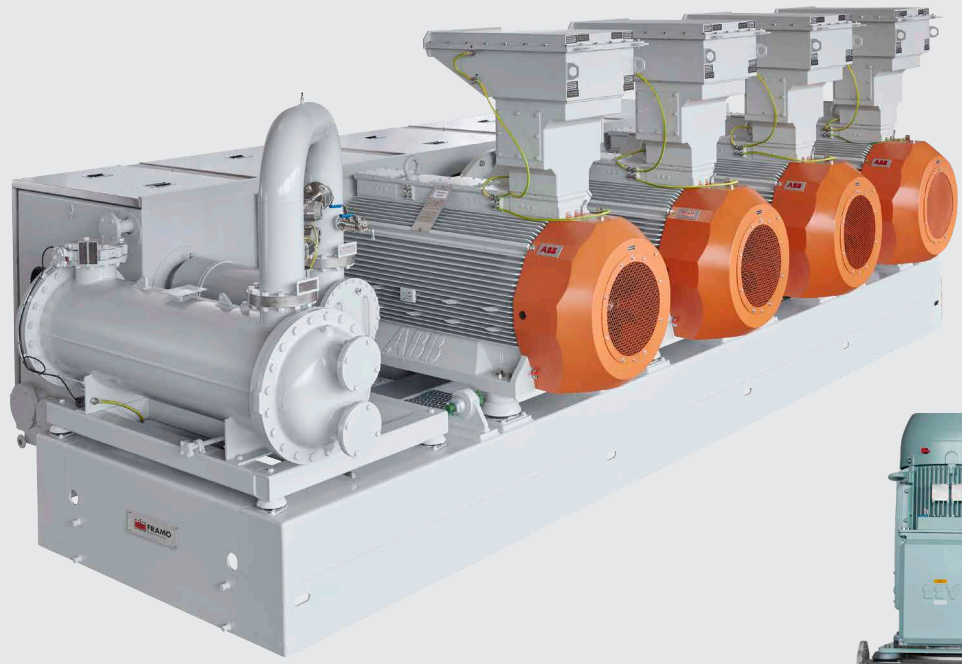

Hydraulic power unit with high voltage electric motor driven power packs for FPSO and FSO applications.



Hydraulic power unit with electric motor driven power packs for small and medium sized tankers.

Control

The hydraulic power unit and all cargo pumps and other consumers are operated and monitored from the Framo control panel.

The control system can be interfaced with ships Integrated Control System.





Framo piping

The need for quality hydraulic installation onboard vessels operating in severe marine environment has led to the development and manufacturing of Framo hydraulic piping systems. The hydraulic piping system is based on high quality components and piping materials.

Quality and competence

Duplex stainless steel on all high pressure pipes and pilot pipes on deck. Stainless steel AISI 316L on all low pressure hydraulic pipes on deck.

The hydraulic pipes are of high standard with smooth internal surface intended for hydraulic oil with high cleanliness. All service valves are made from stainless steel.

The Framo hydraulic piping system is designed with extensive use of cold bending in order to limit the number of flanged connections.

Framo supply specially designed flanges for all pressure ratings, flexible bulkhead penetrations,

resilient pipe clamps, anchor supports, and other accessories for the hydraulic piping system.

Framo has a highly specialized manufacturing plant in Norway for the design and manufacture of all the components in the hydraulic piping system.

Prefabrication of the piping system to any level of complexity from a single spool piece to a full system is available.

In all areas of design special attention is given to reduce vibration and noise from components and pumps. The cargo pumps, hydraulic power units and hydraulic piping are all resilient installed.

Framo can prefabricate piping systems to meet any level of complexity. The high-quality components ensure reliable, robust performance in severe marine environments.

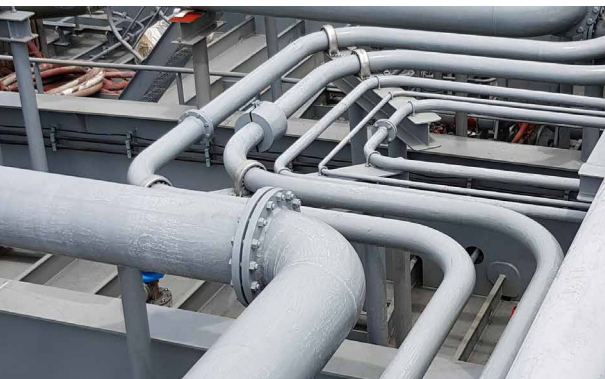
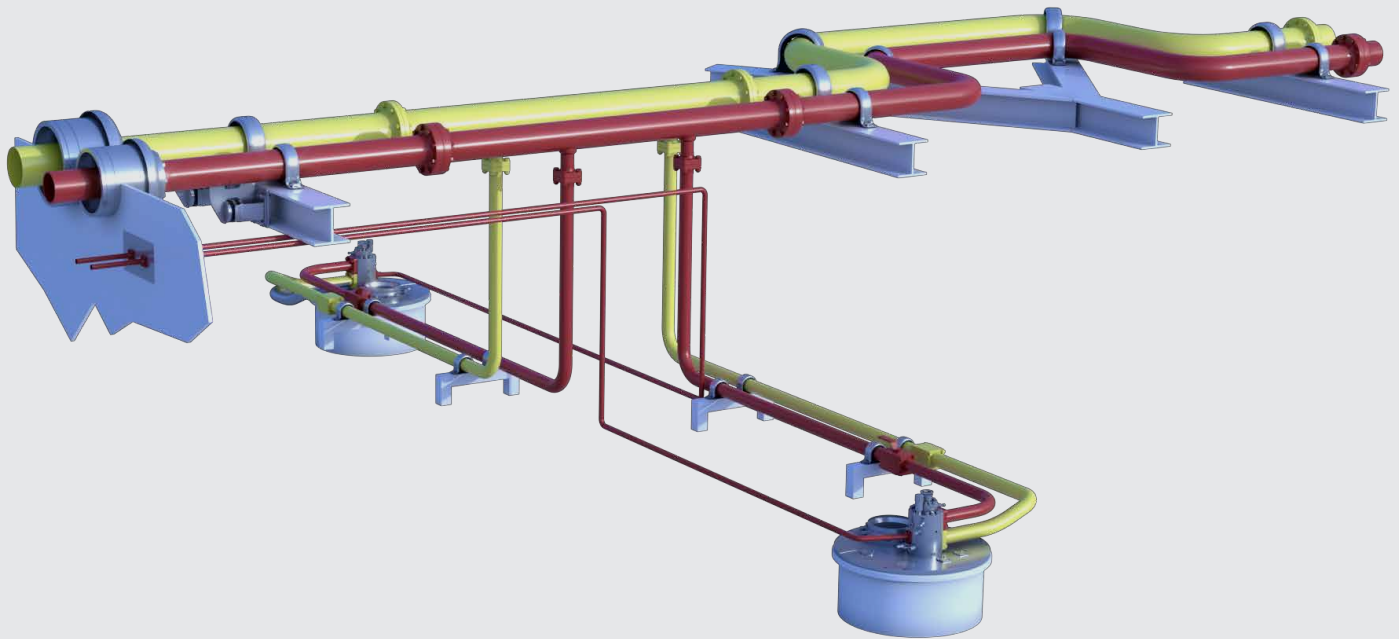

Chemical tanker

M/T "Opera"
36,000 dwt Chemical tanker
Owner: MOL, Japan
Built: Kitanihon, Japan, 2020

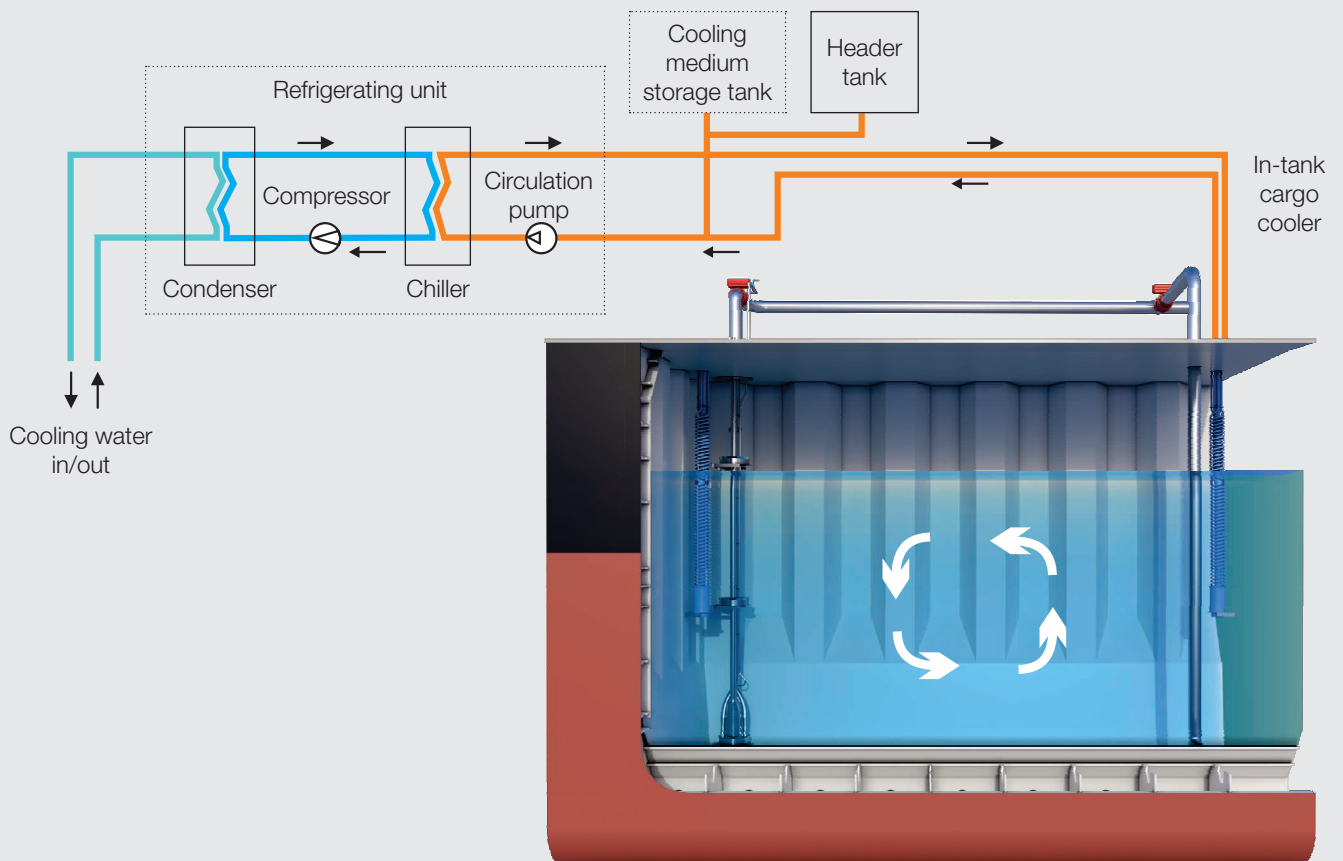

Cargo cooling

The Framo cargo cooling system enables chemical carriers to also transport low-boiling-point cargoes and semi-gases. Cargoes such as Propylene Oxide and Isoprene are often transported on board chemical carriers, which use our cooling system to maintain a safe cargo temperature.

The Framo cargo cooling system comprises individual cargo coolers for each tank, chiller units and a ring-line for the cooling medium. The cargo cooler is installed submerged inside the cargo tank and is equipped with an integrated cargo circulation unit. The Framo cargo cooling system is an independent system that easily can be retrofitted.

Installed inside the tank for maximum safety. Cargoes such as Propylene Oxide and Isoprene should not be circulated outside their tanks.



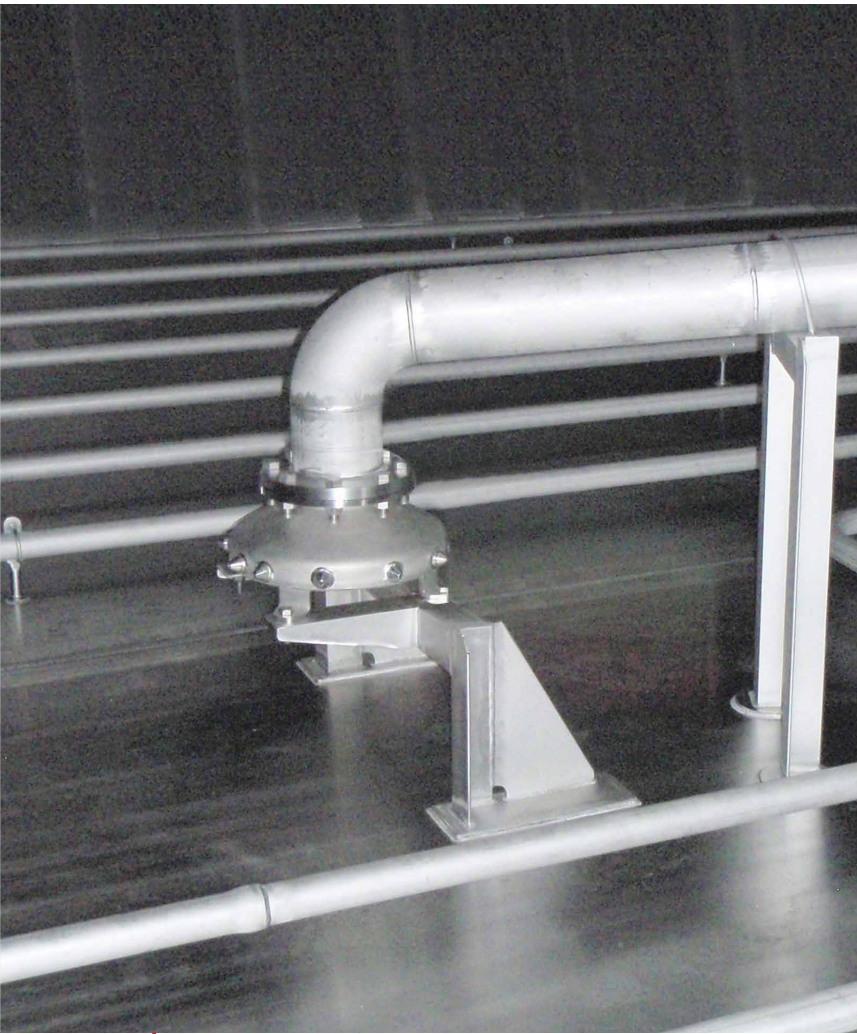

MV "Baru" 83,500 dwt OBO Carrier
 Owner: Klaveness, Norway
 Built: Yangzijiang, China, 2019

OBO carriers

A one-pump-per-hold system that is easy to operate and to clean has been specially designed for combination vessels that are alternating between wet and dry cargoes. The cargo pumps are installed in protective enclosed corrugations between the holds. Cargo piping and cargo heaters are located on deck.

Cargo circulation

To prevent sediments settling on the tank-top during transport and to maintain the liquid quality, a Framo diffuser can be installed on the outlet of the dropline. During voyage cargo is circulated through the diffuser by running the cargo pump at intervals.

The diffusers are specially designed for individual cargo tanks, and each diffuser contains several nozzles, whose number and dimensions are determined on the basis of the dimensions and shape of the tank-top.

Diffusers are normally produced in high-molybdenum stainless steel for exposure to Phosphoric Acid, but are also available in AISI 316L for other cargoes. Forced cargo circulation should be repeated at regular intervals throughout the voyage.

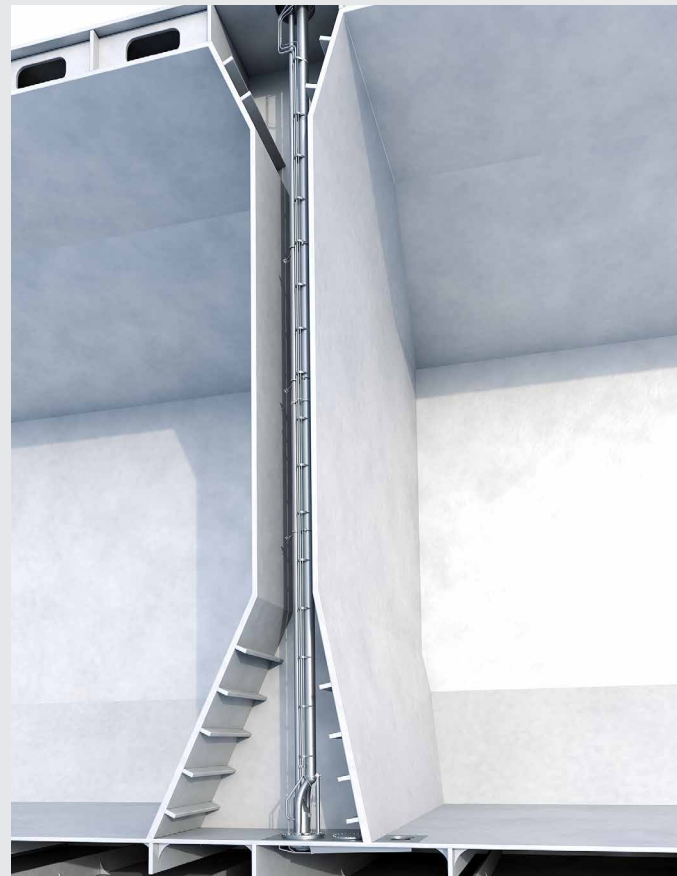

Installation

The OBO cargo pump is installed in a closed corrugation at the aft end of each cargo hold. Only the volute casing of the pump is submerged in cargo inside a suction well, with a free-flow duct connection to the cargo hold. The upper part of the pump-head and the complete pipe-stack remain dry within the corrugation, which may be regarded as a standard cofferdam.

FPSO "Glen Lyon"
Built: Samsung Heavy Industries, Korea.

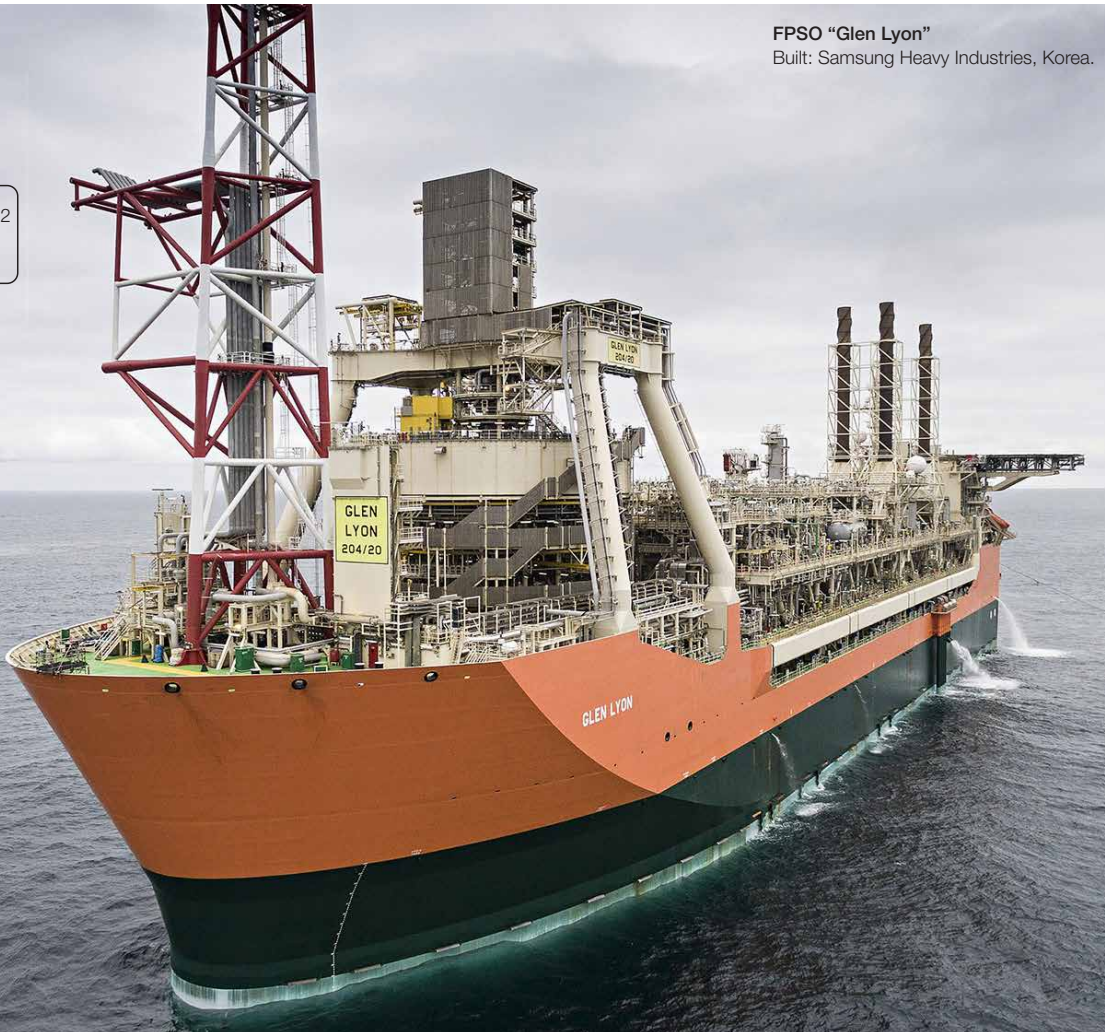

Floating production, storage and offloading

FPSOs explore oil from remote and deepwater locations under harsh environmental conditions. The highest standards for safety and operation regularity apply to design concepts and equipment. A reliable cargo offloading system is key to FPSO production uptime.

Safety and operation regularity

Framo submerged offloading pumps use hydraulic drive technology developed through extensive experience from the tanker industry and further refined for FPSO applications.

The hydraulic motor is located close to the impeller, connected with a short rigid shaft. The motor and shaft assembly is continuously lubricated and cooled by the hydraulic drive oil.

The Framo pump design provides a technically sound construction that allows for transmission of high pumping power and is particularly suitable for deep storage tanks.

Framo offloading pumps are equipped with stepless capacity regulation, ensuring that the flowrate and pressure head can meet any variation of FPSO pumping requirements.

In-tank offloading pumps provide safe offloading conditions. Pump room and in-tank suction lines are avoided. Each tank is effectively isolated for safe tank entry. International classification societies and regulative bodies advise the use of submerged offloading pumps for FPSOs.



Semi FPS "Gumusut-Kakap"
 Built: Malaysian Marine and Heavy Engineering (MMHE)
 Service in Malaysia since 2014.



FPSO "P-54" 2 mill bbls for Petrobras.
 Conversion: VLCC.
 Service in Brazil since 2008.



Prelude FLNG for Shell and INPEX
 Built: Technip / Samsung Consortium (TSC) in South Korea
 Service in Browse Basin, Australia since 2017



Operating conditions

- 50 – 250,000 bbls/day production rate
- 10 – 40 years of field operation
- Offload crude oil at required flow rate
- Crude oil transfer between tanks
- Shift produced water and skimmed oil from settling tanks
- Tank interior cleaning during offloading operations
- Effectively drain the storage tanks when required for tank inspection and/or entry

Performance

Hydraulic power transmission offers a safe design that effectively avoids overload as well as over-speed, and pump capacity regulation means efficient tank stripping. Pump material selections range from AISI316L to 254SMO.

Field specific

Framo hull tank pump systems for FPSO applications are designed to field specific crude oil properties and project specific redundancy requirements.

Redundancy

System designs can be configured for 1x100%, 2x50% and 2x100% submerged pumps per tank, with hydraulic power systems to meet required pump duties.

Pump system applications

Applications for Framo FPSO and FSO pumping solutions include:

- Cargo offloading
- Hull process tanks
- Slop tanks
- Slop skimming
- Produced water
- MEG systems
- Flow assurance chemicals
- Hull ballast and deballasting

Technical data

Cargo pumps

	A (mm)	B (mm)	C (mm)	D (mm)	Cargo flange	Weight of 10 m pump (kg)	Weight per m (kg)
SD 100	318	30	394	500	DN100	325	24
SD 125	448	30	524	500	DN125	500	28
SD 150	496	30	574	500	DN150	550	30
SD 200	635	40	715	500	DN200	950	46
SD 250	710	60	810	500	DN250	1150	53
SD 300	896	65	1025	500	DN300	1500	65
SD 350	1000	100	1100	500	DN350	2350	80

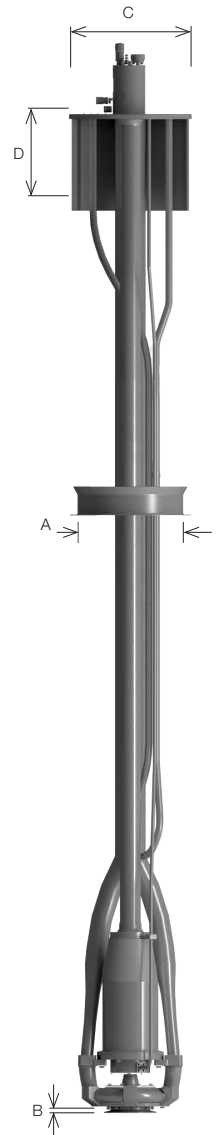

Capacity range

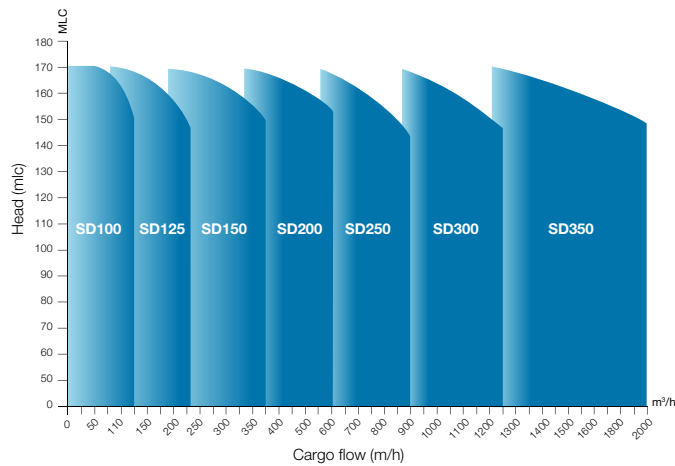

Stainless steel qualities

Qualities	Description chemical composition % (mass)							Approximate Equivalent		
	C MAX	Si MAX	Mn MAX	Cr	Ni	Mo	Cu	USA AISI	EUROPE EN	JAPAN JIS
Standard acid resistant low carbon content	0,03	1,0	2,0	16,5 18,5	10,5 13,0	2,5 (2,7) 3,0	–	316L	1.4432	SUS 316L
Special acid resistant high nickel content (2 RK 65)	0,02	0,7	2,0	19,0 21,0	24,0 26,0	4,0 5,0	1,2 2,0	904L	1.4539	
254SMO	0,02	0,07	1,0	20,5 19,5	0,25 0,18	7,0 6,0	1,0 0,5		1.4547	

Suction wells

Stainless steel suction wells pressed to shape.



Ballast pumps

	Capacity (m ³ /h)	A (mm)	B (mm)	C (mm)	D (mm)	Weight of 10 m pump (kg)	Weight pr m (kg)
SB 125	250	755	408	150	125	510	18
SB 200	500	790	596	250	200	550	18
SB 300	1000	1121	735	350	300	840	18
SB 400	2000	1630	1100	450	400	1540	30
SB 600	3000	1710	1250	600	500	2350	30

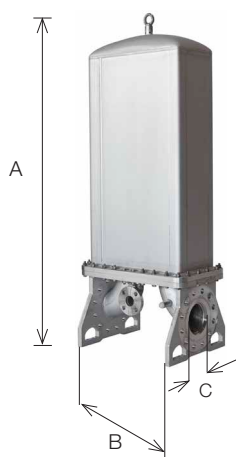

Cargo heaters

	Capacity (kw)	A (mm)	B (mm)	C (mm)	Weight (kg)
HE 225	360	1200	366	100	175
HE 430	800	1600	560	160	425
HE 500	1600	1637	700	160	500

Portable pumps

	TK 80	TK 100	TK 150
Capacity (m³/h)	70	150	300
Head	70 mwc	70 mwc	60 mwc
Material	AISI 316L	AISI 316L	AISI 316L
Weight (kg)	25	32	78
Pumphead (mm)	ø250	ø300	ø300
Height (mm)	625	482	598

The Framo cargo pumping system is equipped with a portable pump type TK80 or TK150 in accordance with class requirements for "a secondary means of unloading".

Hydraulic drive outperforms any other power transmission for pumping extremely viscous cargoes. For emergency cargo unloading, an extended range of portable pumps models and hydraulic power units is available for rental.



All pumps are individually run and tested with respect to capacity, head, hydraulic pressure and oil flow. The Framo system is delivered according to the requirements of any classification society and national or international maritime authorities.

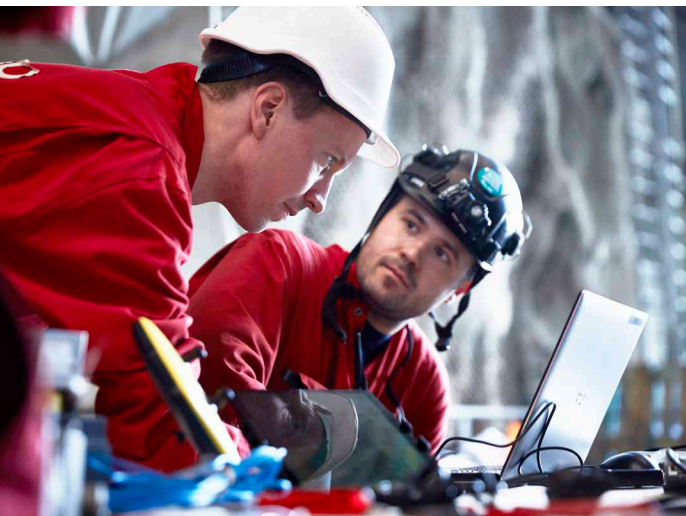
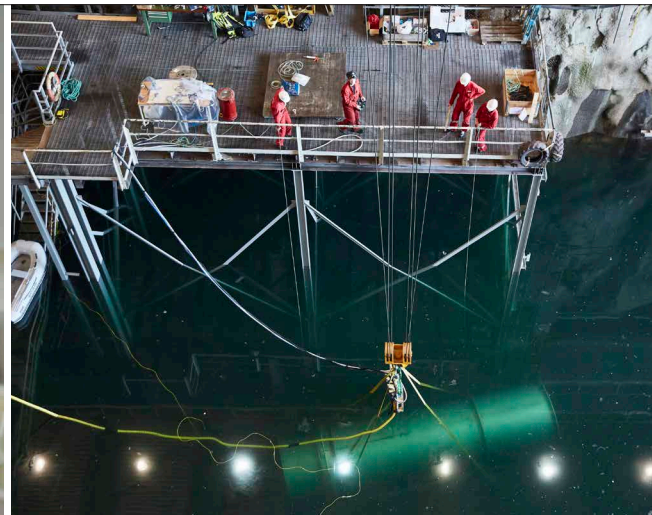

Research and development

Framo aim to supply the safest cargo pumps there are, designed for handling the most difficult cargoes carried on tankers. Excellent performance will contribute to the improved profit for owners and charterers.

Safeguarding future improvements

Research and extensive testing is the very foundation for the development of Framo cargo pumping systems for tomorrow. The tanker industry's operational and safety requirements, as well as international maritime legislation, are getting stricter by the years. The awareness of the hazards of carrying liquid cargo in bulk, and the potential damage it can cause to people and environment in case of an accident has become a top priority issue.

Performance

We have a fully integrated company securing high and uncompromised quality in all areas of our business. We continuously work to improve system performance and reliability. In close dialogue with our customers world wide we learn and benefit from their vast operational experience from ships in service.

Testing

Full scale testing facilities and our in-house dry dock with stainless steel deep tanks give us the advantage of special testing or testing out new ideas in full.



M/T "Eco California"
50,000 dwt Chemical tanker
Owner: Central Mare, Greece
Built: HMD, Korea, 2019



Framo In-Tank Eye

The process of swapping cargo poses extreme challenges, especially when working with volatile or hazardous liquids. The need to manually inspect tanks with a confined space entry (CSE) can put crew safety at risk. And the procedures to mitigate that risk are elaborate and time consuming, requiring, among other things, the costly process of gas-freeing and re-inerting cargo tanks.

The Framo In-Tank Eye is an explosion-proof, portable, camera-based solution that eliminates these challenges. With a camera inserted into the tank via the cargo pump, crew members can remotely watch a livestream of the cargo stripping process on a display monitor. This minimizes the need to physically send surveyors into the tank to verify the remainder on board (ROB) levels.

No major modifications are needed to install the in-tank eye thanks to a smart design that utilizes existing penetrations for tank entry. The camera is certified for safe operation in zone 0 according to the strict IECEx standards. The display monitor is certified for zone 1 operation.





Customer support

Framo AS service organization provides technical support during the installation phase of a project, as well as professional service throughout the lifetime of the vessels. Condition based maintenance and correct operation are the best ways of ensuring optimal equipment performance. The Framo service organization is there to support you 24/7.

Commissioning

Framo engineers provide assistance and guidance during installation of the cargo pumping system at the shipyard. Installation, start-up and testing of the system is carried out under our supervision in close co-operation with the yard and the ship owner.

Training

Framo Training School organizes seminars and tailor-made courses at Framo training facilities in Bergen, Rotterdam, Houston, Singapore, Pusan, Tokyo, Shanghai and at the Norwegian Training Centre in Manila.

Framo seminars qualify the participants for a course certificate. The Framo programme also comprises training at the yard upon vessel delivery as well as on-board training.

Service bulletins

Technical updates are distributed to help owners and operators to best utilize the installed Framo Cargo Pumping System.



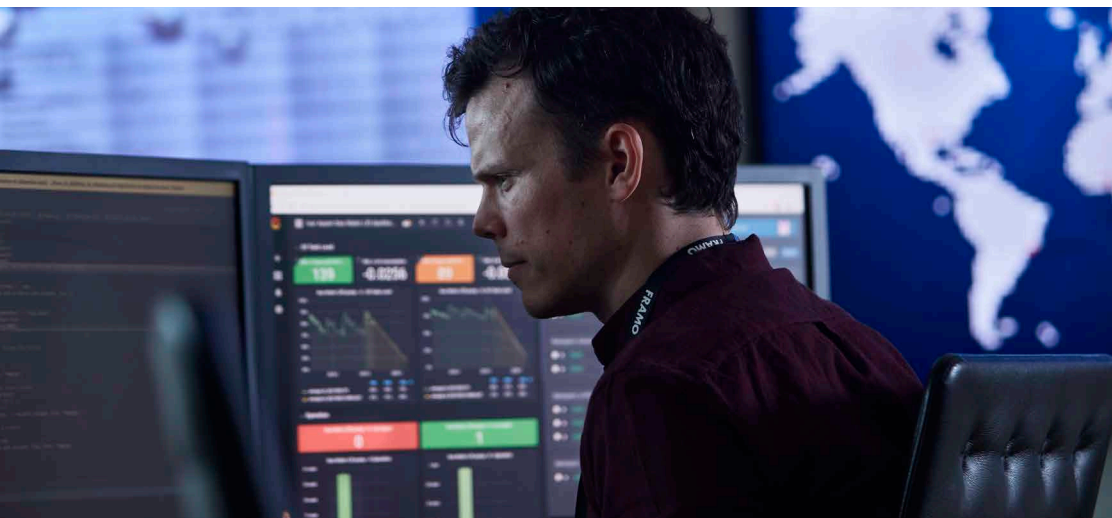

Service and repairs

To safeguard a high system availability, annual inspection, pre-docking inspection and hydraulic oil monitoring program can be provided.

Advisory service in connection with system operation, service or repair is available.

Framo engineers are available when required.

Spare parts

Our own service and repair facilities located in Bergen, Rotterdam, Houston, Singapore, Busan, Tokyo, Shanghai and Rio de Janeiro have spare parts in store to suit all the Framo systems in operation.

Condition based exchange of wear and tear parts reduces your operation cost and ensures that your cargo pumps perform with optimal capacity at all times.

We are available around the clock.



Chemical tanker

The delivery of Utkilen's new vessel "Saltstraum" in May 2020, was ship number 4,000 in operation to be fitted with Framo pumps. The vessel has capacity for 10 500 tonnes cargo in a total and 14 different stainless-steel cargo tanks, all fitted with Framo pumps. The main engines have been designed for use of natural gas (LNG) as fuel, and the ships can also be fitted with battery propulsion in the future.

M/T "Saltstraum"
10,500 Chemical tanker
 Owner: Utkilen, Norway
 Built: Avic Dingheng, China, 2020



Founded in 1938

Framo AS is based in Bergen, Norway. From its beginning in 1938, the company has grown into a worldwide organization with subsidiaries on three continents. Today Framo AS with 1200 employees is a leading manufacturer of submerged pumping systems for the tanker shipping and offshore industry. We work actively with our customers and provide competence and experience. With dedication, structured work and continuous improvements we develop tomorrow's pumping systems. Framo is a part of Alfa Laval and Bergen is the headquarter for Marine pumping systems. The Framo products are sold and serviced by Framo only.

FRAMO

an Alfa Laval brand



**Head office FRAMO AS**

P.O. Box 23, NO-5329 Florvåg, Norway
Phone: +47 55 99 90 00
E-mail: marine@framo.no

framo.com

FRAMO Nederland

Edisonweg 18
P.O. Box 305
NL-3200 AH Spijkenisse
The Netherlands
Phone: +31 181 619311
nederland@framo.no

FRAMO Houston

3002 East 13th Street
La Porte, Texas 77571, USA
Phone: +1 281 884 4800
houston@framo.no

FRAMO Singapore

17 Tuas View Circuit
Singapore 637575
Republic of Singapore
Phone: +65 6210 2400
singapore@framo.no

FRAMO Nippon

Kotsu Building 5F, 15-5
Shinbashi, 5-chome
Minato-ku
Tokyo 105-0004, Japan
Phone: +81 3 5776 2405
tokyo@framo.no

FRAMO Korea

Rm 608, Centum Sh Valley
35, Centum Dong – Ro
Haeundae – Gu, Busan
Korea, 612-020
Phone: +82 51 743 6942/3
busan@framo.no

FRAMO Shanghai

Building No.5, 123
Lane 1165, Jin Du Road
Min Hang District, Shanghai
China 201108
Phone: +86 21 6115 5000
shanghai@framo.no

FRAMO do Brasil

Av. Presidente Vargas, 463
/19º andar, Rio de Janeiro
CEP 20071-003, Brazil
Phone: +55 21 2507 7898
brasil@framo.no

**FRAMO Services Branch
Office Dubai**

Al Quoz Industrial Area
P.O. Box 21467
Dubai, United Arab Emirates
Phone: +971 4 346 9143
dubai@framo.no

FRAMO Service

P.O. Box 44
NO-5329 Florvåg, Norway
Phone: +47 55 99 92 00
service@framo.no

FRAMO Fusa

Venjanaset
NO-5641 Fusa, Norway
Phone: +47 55 99 96 00
marine@framo.no

FRAMO Holsnøy

Rosslandsvegen 933
NO-5918 Frekhaug, Norway
Phone: +47 55 99 75 00
piping.marine@framo.no

FRAMO Flatøy

Flatøyvegen 24
NO-5918 Frekhaug, Norway
Phone: +47 55 99 94 00
oil&gas@framo.no